

TOP VIEW

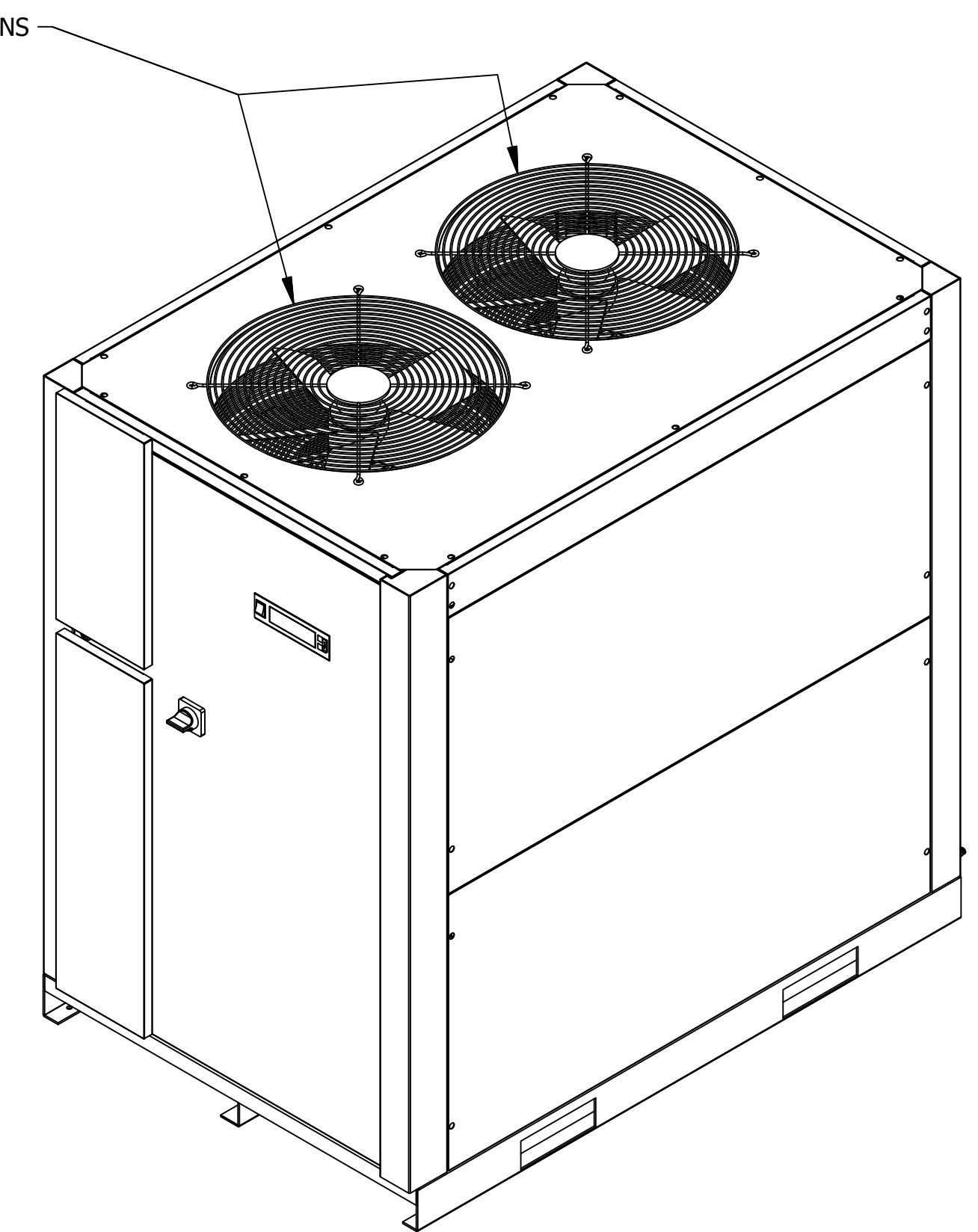

SERVICE:
COMPRESSED AIR

DRYER INFORMATION:
INLET AIR FLOW: 1500 SCFM | 42.5 Nm³/min
CONNECTIONS: 4" CLS 150 RF FLG
REFRIGERANT: R407C
ELECTRICAL: 460V/3PH/60Hz
WEIGHT: 1766 LBS. / 801 KG

OPERATING CONDITIONS:
RATED INLET AIR PRESSURE: 100 PSIG / 6.9 BARG
MAXIMUM INLET AIR PRESSURE: 232 PSIG / 16 BARG
MINIMUM INLET AIR PRESSURE: 44 PSIG / 3 BARG
RATED INLET AIR TEMPERATURE: 100°F / 38°C
MAXIMUM INLET AIR TEMPERATURE: 122°F / 50°C
MINIMUM INLET AIR TEMPERATURE: 39°F / 4°C
RATED AMBIENT AIR TEMPERATURE: 100°F / 38°C
MAXIMUM AMBIENT AIR TEMPERATURE: 113°F / 45°C
MINIMUM AMBIENT AIR TEMPERATURE: 36°F / 2°C

SPECIFICATIONS:
CONDENSER TYPE: AIR COOLED
DRAIN TYPE: ELECTRONIC AUTO DRAIN VALVE
EXPANSION DEVICE: CAPILLARY TUBES

- NOTES:**
- THIS DRAWING ALONG WITH THE MANUAL PROVIDES OPERATING CONDITIONS, SPECIFICATIONS, INSTALLATION, MOUNTING, AND CONNECTION REQUIREMENTS. READ THE MANUAL PRIOR TO INSTALLATION.
 - INSTALL IN A CLEAN, WELL VENTILATED AREA TO REDUCE DIRT AND DUST ON THE CONDENSER COILS.
 - FOR COOLING AIR FLOW AND MAINTENANCE PURPOSES, RECOMMENDED CLEARANCE AROUND UNIT IS 4 FEET [1220 MM].
 - INSTALLATION CONSTRAINTS. ON-SITE ASSEMBLY OF PIPING, TUBING AND/OR ELECTRICAL CONNECTIONS, ARE THE RESPONSIBILITY OF THE CUSTOMER/OWNER.

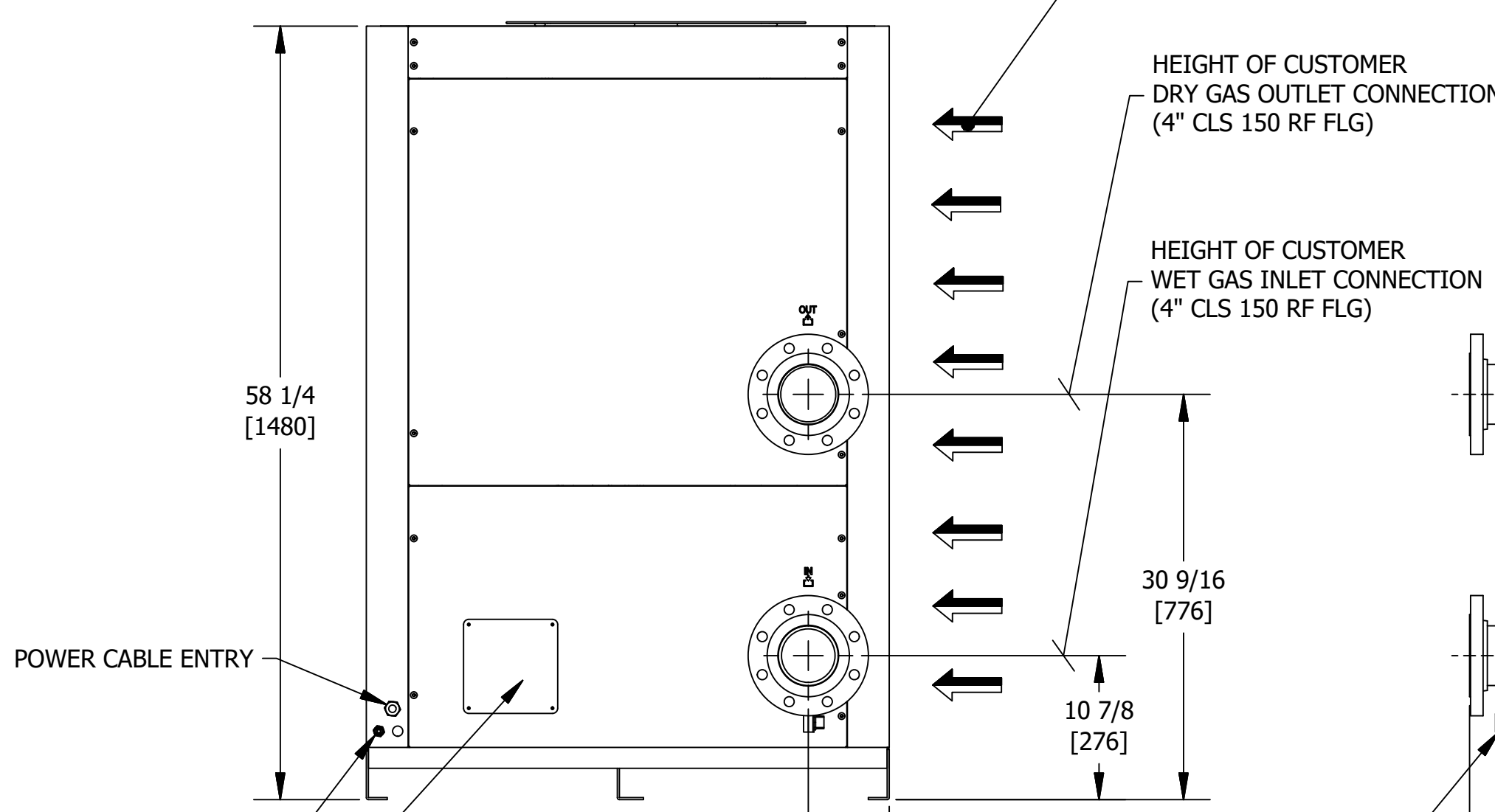
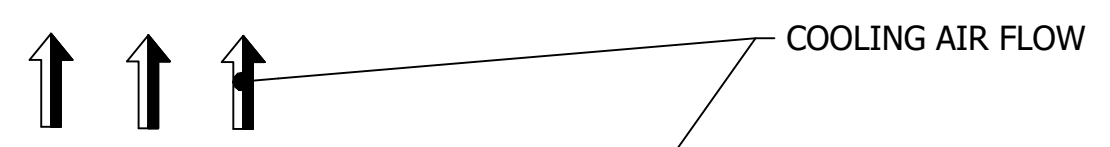

REAR VIEW

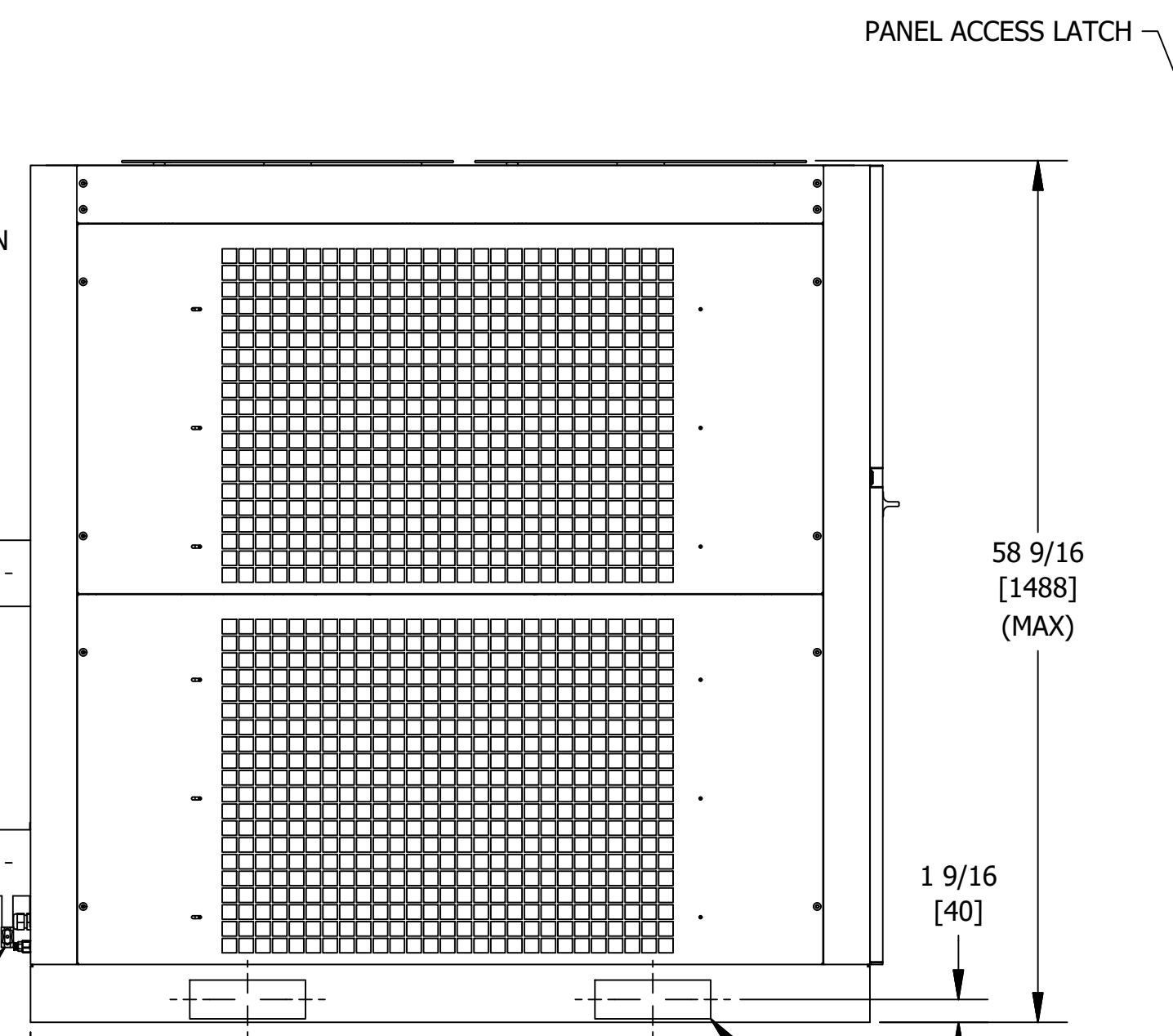

SIDE VIEW

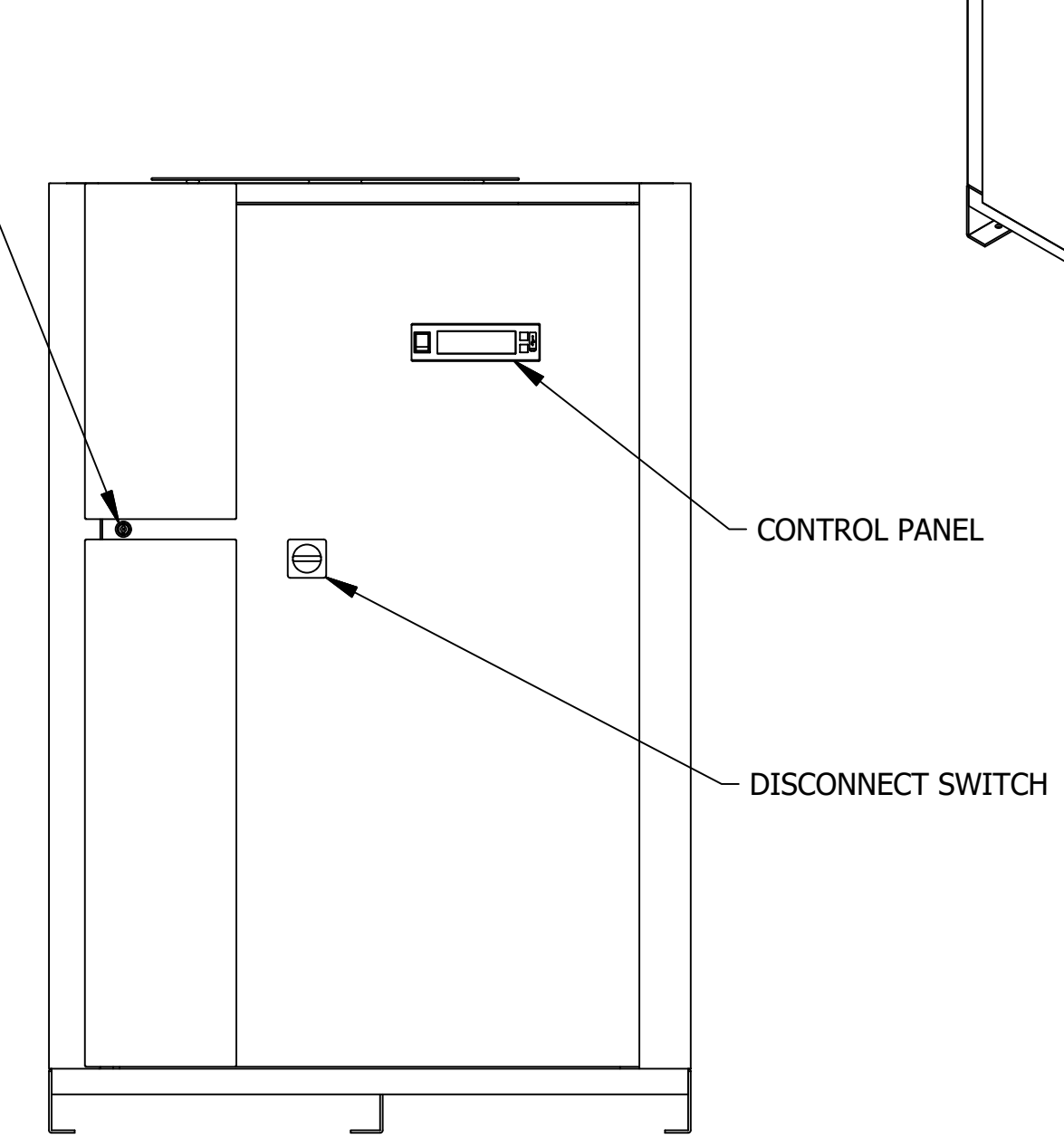

FRONT VIEW

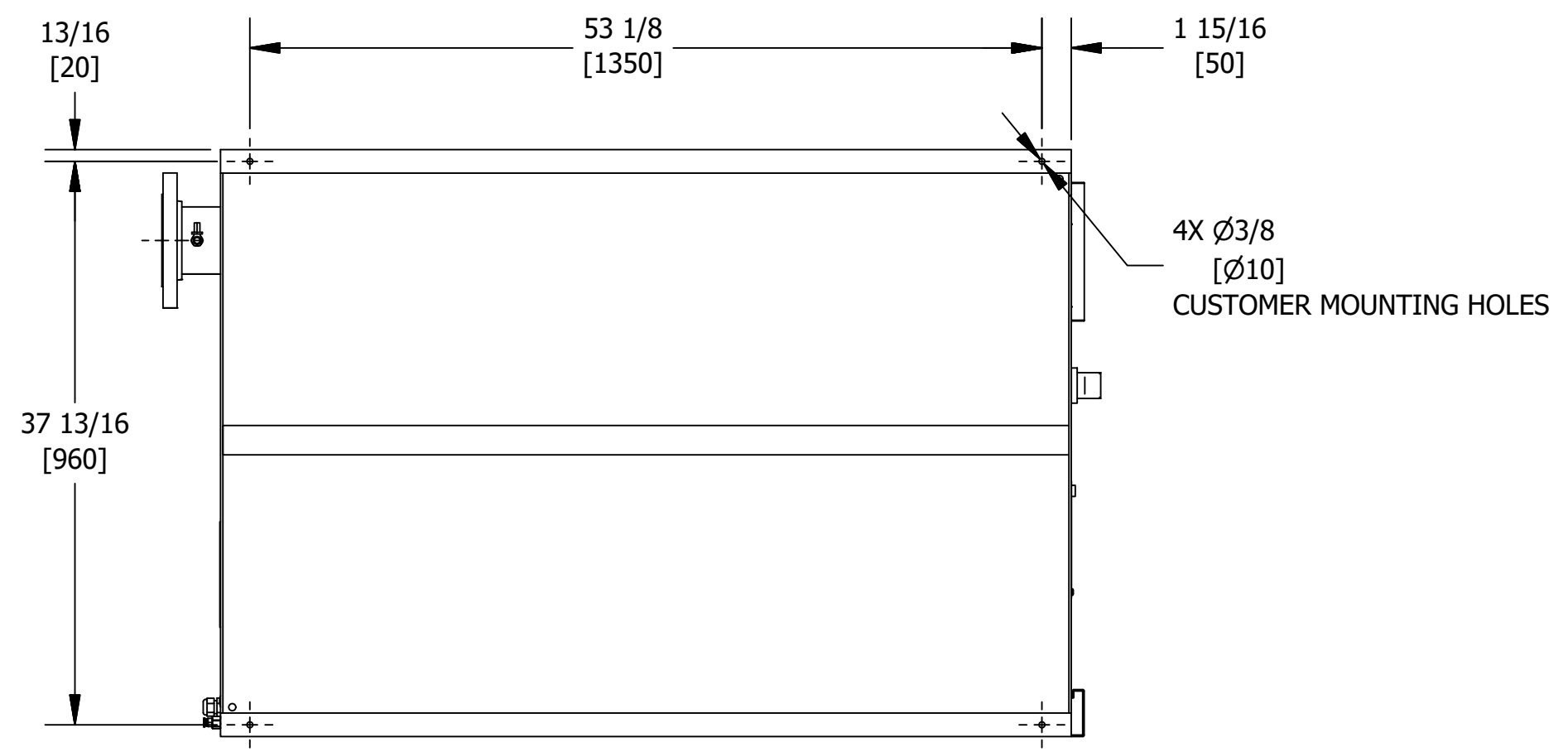

FOOT PRINT

UNLESS OTHERWISE SPECIFIED:		NAME	DATE	UNAUTHORIZED USE, MANUFACTURE, OR REPRODUCTION IN WHOLE OR IN PART IS PROHIBITED. DRAWING DESIGN AND OTHER DISCLOSURES ARE PROPERTY OF:
DIMENSIONS ARE IN: INCHES (MM)		DWN BY	CRH	
SURFACE FINISH: N/A		ENG BY	BJM	8/2/2019
TOL.	MM	INCHES	CHK BY	BJM
.X			APP BY	DEH
.XX			REL BY	MDB
.XXX			MAT NO:	
FRACT: ±1/2	ANG: ±2°			SIZE DWG NO: D GA03DEL-0202
SCALE: 3/32			REV: 1	SHEET 1/1



GENERAL ARRANGEMENT
DFX 15.1